



# HIGHVELD AMATEUR RADIO CLUB

## SHACKNEWS

PO Box 19937 Sunward Park 1470      MAY 2007

Website    <http://www.qsl.net/zs6hvb/>    e-mail    zs6hvbinfo@zs6ro.co.za  
<http://www.qsl.net/zs6ssc/>

Sunday morning BULLETINS - 145.7875 MHz & 7062 KHz @ ±08h45.

### COMMUNICATION IS THE NAME OF THE GAME

**Meeting** At the meeting held on Saturday 2<sup>nd</sup> June we had a visit from Jaap Lourens ZS6SAI. Jaap is an interference investigator from Sentech. He gave an enlightening talk on the operations of Sentech and how he fits into their operation. Most interesting was the mortuary fridge that interfered with the TV reception at a block of flats. Never a dull moment hi. The meeting ended with plenty to eat and drink. At the next meeting OM Frank, ZS6TMV, will be giving a talk on the Magnetic Loop Antenna with a demo unit.

**SSC Meeting** This was held at the home of Errol and Betty. Nice social turnout amateurs and their wives. Thanks to Errol and Betty for the catering and all the others who brought eats along. Certainly did not need supper that evening. The next get together will be held at the home of Doug and Merle on 14<sup>th</sup> July.

---oooOOOooo---

A 60-year-old man went to a doctor for a check-up. The doctor told him, "You're in terrific shape. There's nothing wrong with you. Why, you might live forever; you have the body of a 35-year-old. By the way, how old was your father when he died?"

The 60-year-old responded, "Did I say he was dead?"

The doctor was surprised and asked, "How old is he and is he very active?"

The 60-year-old responded, "Well, he is 82 years old and he still goes skiing three times a season and surfing three times a week during the summer."

The doctor couldn't believe it. So, he asked, "Well, how old was your grandfather when he died?"

The 60-year-old responded again, "Did I say he was dead?"

The doctor was astonished. He said, "You mean to tell me you are 60 years old and both your father and your grandfather are alive? Is your grandfather very active?"

The 60-year-old said, "He goes skiing at least once a season and surfing once a week during the summer. Not only that," said the patient, "my grandfather is 106 years old, and next week he is getting married again."

Chairman:	Doug Wetton	ZS6BXU	011-680-4906
Vice Chairman	Frank van Wensveen	ZS6TMV	011-942-3657
Secretary / Treasurer:	Berridge Emmett	ZS6BFL	011-893-1291
Repeater/Packet Radio/Technical	Ton Van Dijk	ZS6ANA	011-942-3657
Shacknews Editor:	Berridge Emmett	ZS6BFL	011-893-1291
Shacknews-Print & Posting:	Harry Lautenbach	ZS6LT	011-888-5362
Website Manager	Yvonne Van Dijk	ZR6TBL	011-942-3657
QSL Manager:	Vacant		

The doctor said, "At 106-years, why on earth would your grandfather want to get married?"

His patient looked up at the doctor and said, "Did I say he wanted to?"

---oooOOOooo---

VOX operated switch for a PTT or tape recorder

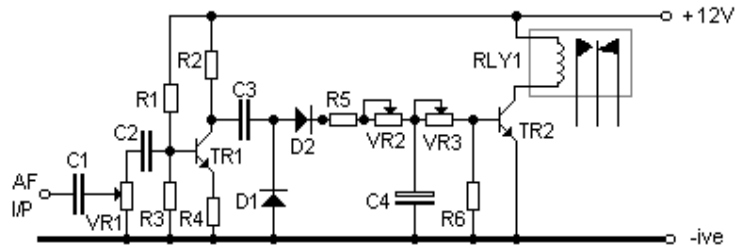

Vox Operated Switch Unit

VR1 = A.F Gain

VR2 = Activation delay

VR3 = latched decay

R1=1M	C1=0.01	TR1=BC546
R2=4.7K	C2=0.01	TR2=BC546
R3=220K	C3=0.01	D1=1N4148
R4=1.2K	C4=47uF	D2=1N4148
R5=12K	VR1=470K	
R6=100K	VR2=100K	
	VR3=100K	

---oooOOOooo---

## AAADD

That's Age-Activated Attention Deficit Disorder to you, and here's how it goes ...

I decide to wash the car and start toward the garage, when I notice the mail on the table. I figure I might as well go through the mail before washing the car.

I lay my keys down on the desk, sort the mail and discard the junk mail. As I discard the junk mail, I see that the garbage can is full.

I lay the bills down on the desk and pick up the trashcan. Then I figure that since I'll be going near the mailbox while taking out the trash, I may as well pay these few bills first. Now where did I put my checkbook?

Ah, here it is! Oops, there's only one check left. My extra checks are in the other room.

Oh! There's the soda I was drinking earlier! Hmmm, I guess I'd better take it out to the kitchen and discard it.

On the way to the kitchen, my flower arrangement catches my eye and I realize it

Chairman:	Doug Wetton	ZS6BXU	011-680-4906
Vice Chairman	Frank van Wensveen	ZS6TMV	011-942-3657
Secretary / Treasurer:	Berridge Emmett	ZS6BFL	011-893-1291
Repeater/Packet Radio/Technical	Ton Van Dijk	ZS6ANA	011-942-3657
Shacknews Editor:	Berridge Emmett	ZS6BFL	011-893-1291
Shacknews-Print & Posting:	Harry Lautenbach	ZS6LT	011-888-5362
Website Manager	Yvonne Van Dijk	ZR6TBL	011-942-3657
QSL Manager:	Vacant		

needs more water. I pour the soda down the sink.  
 As I wipe a spot off the counter I see my glasses on the windowsill. It's about time. I've been looking for them all morning!  
 I guess I'd better go put them away so I can find them again later. But first I've got to add water to the flower arrangement...  
 Hey! What's the TV remote doing in the kitchen? Aaaaaaagh! I'd better take it to the living room, because we'll never think to look for it in the kitchen tonight.  
 I take the remote out to the coffee table and find that the living room is a bit untidy, so I go around arranging cushions and throw pillows.  
 Then I'm off down the hall, to... to... what the heck was I planning to do?  
 End of day: The car isn't washed, the bills are unpaid, the flowers aren't watered, the checkbook still only has one check, and now I can't seem to find my car keys! I don't seem to have gotten anything done today, but I just can't figure out why because I KNOW I WAS BUSY ALL DAY LONG!!!  
 I realize this is a serious condition and that I'd better seek help. But first, I think I'll check my e-mail.

Thanks to whoever is the author of this article on AAADD

---oooOOOooo---

WALKIIE-TALKIE weighing in at 12.5 Kg (QST January 1949)

**SCR-195 WALKIE-TALKIES**

SCR 195 Walkie Talkies, brand new, weight 27½ pounds, including knapsack. Range up to 25 miles in open country. Frequency 52.8 to 65.8 MC. Transmitter and receiver with regular hand set. Complete ready to operate with spare parts.



**\$59.95**

Price per set of 2 **\$115**

Equals 5 x 2.5 Kg bags of flour

Chairman:	Doug Wetton	ZS6BXU	011-680-4906
Vice Chairman	Frank van Wensveen	ZS6TMV	011-942-3657
Secretary / Treasurer:	Berridge Emmett	ZS6BFL	011-893-1291
Repeater/Packet Radio/Technical	Ton Van Dijk	ZS6ANA	011-942-3657
Shacknews Editor:	Berridge Emmett	ZS6BFL	011-893-1291
Shacknews-Print & Posting:	Harry Lautenbach	ZS6LT	011-888-5362
Website Manager	Yvonne Van Dijk	ZR6TBL	011-942-3657
QSL Manager:	Vacant		

## Hidden transmitter detector

This Circuit is a low gain wideband Tuned Radio Frequency receiver detecting from 500KHz to 600MHz. Upon detecting a signal the LED will illuminate. The detection range from a BUG is variable between 1 and 10meters by adjusting the 47K Preset. OA71 germanium detector diode can be replaced by a 1N4148 silicone rectifier diode but the range is less. If a 4.7uH choke is unavailable wind 5 turns of 22SWG enamel copper around a 5mm Air former. The LED limiting resistor can be lowered to 330R (ohms) if 6Volts is being used. To increase the range of the detector use a 20cm telescopic antenna and another for a ground plane connected to the 0ve(negative).

This circuit could have other uses.

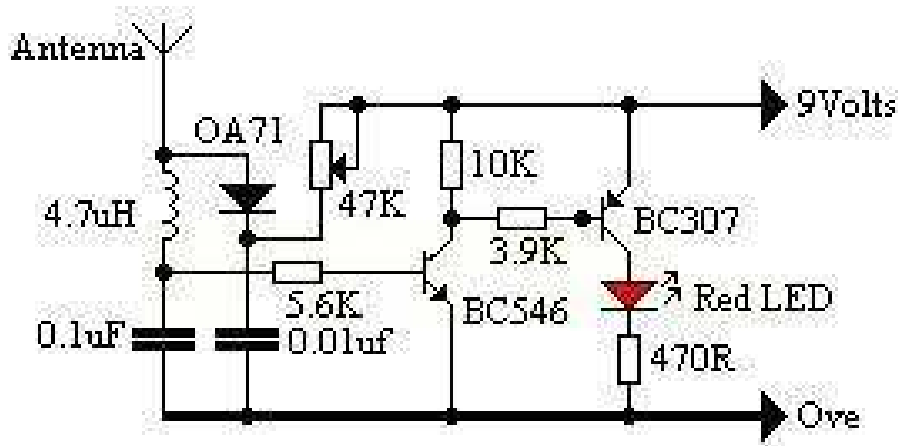

73 Berridge ZS6BFL

Chairman:  
 Vice Chairman  
 Secretary / Treasurer:  
 Repeater/Packet Radio/Technical  
 Shacknews Editor:  
 Shacknews-Print & Posting:  
 Website Manager  
 QSL Manager:

Doug Wetton  
 Frank van Wensveen  
 Berridge Emmett  
 Ton Van Dijk  
 Berridge Emmett  
 Harry Lautenbach  
 Yvonne Van Dijk  
 Vacant

ZS6BXU  
 ZS6TMV  
 ZS6BFL  
 ZS6ANA  
 ZS6BFL  
 ZS6LT  
 ZR6TBL

011-680-4906  
 011-942-3657  
 011-893-1291  
 011-942-3657  
 011-893-1291  
 011-888-5362  
 011-942-3657